

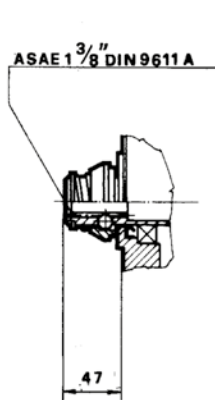

- ACCOPPIATORE POMPE Gr. 3-3,5
- ACCOUPLER POUR POMPE Gr. 3-3,5
- PUMP COUPLING GEAR Gr. 3-3,5
- KUPPLUNGSGETRIEBE FÜR PUMPEN Gr 3-3,5

SERIE: 90000

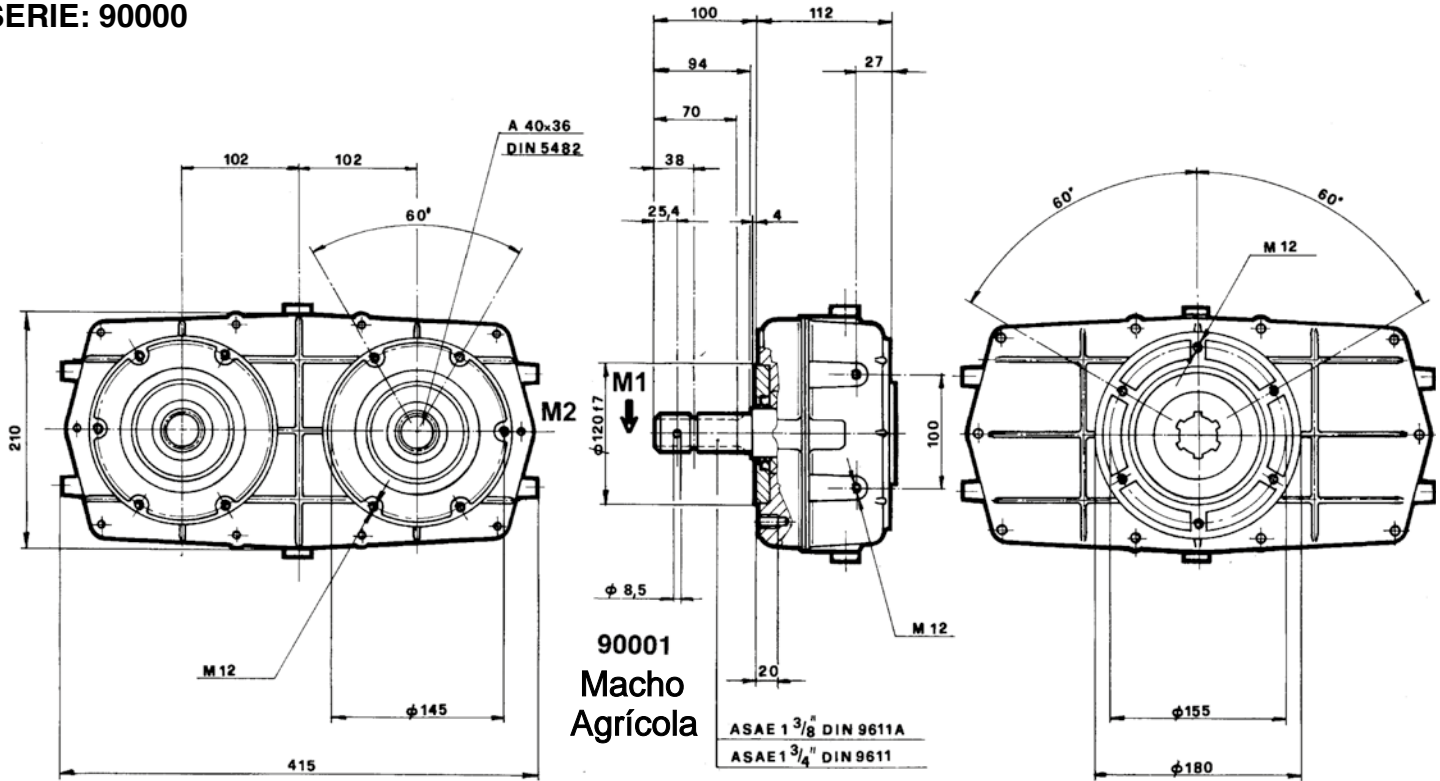

90003

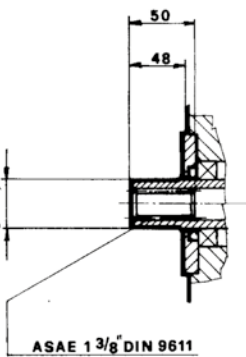

90002
Hembra Larga

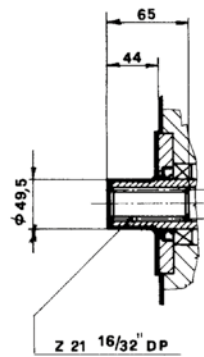

90004
Hembra Larga Z-21T

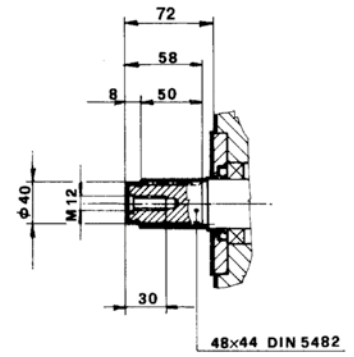

90005
Macho 48X44 Z-23T

Hembra Ataque Rápido

Nivel Max. Aceite: 1,8 lts

M1 da Nm	M2 da Nm	N. 1 giri/1' tours/1' R.P.M U/min	N. 2 giri/1' tours/1' R.P.M U/min	I N.1/N.2	POTENZA Kw	G Kg
93,4	46,6	540	540	1	45	18
96	32	540	810	1,5	45	18
96,8	24,2	540	1080	2	45	18
93,6	18	540	1408	2,5	45	18
97,8	16,3	540	1620	3	45	18
91,8	13,1	540	1836	3,5	45	18
95	12	540	2052	3,8	45	18
94,40	11,8	540	2160	4	45	18
94	9,8	540	2592	4,8	45	18



- TAVOLA RICAMBI ACCOPPIATORE Gr. 4
- TABLEAU PIECES DETACHEES ACCOUPLER Gr. 4
- COUPLING GEAR SPARE PARTS TABLE Gr. 4
- ERSATZTEILLISTE KUPPLUNGSGETRIEBE Gr 4

SERIE: 91000

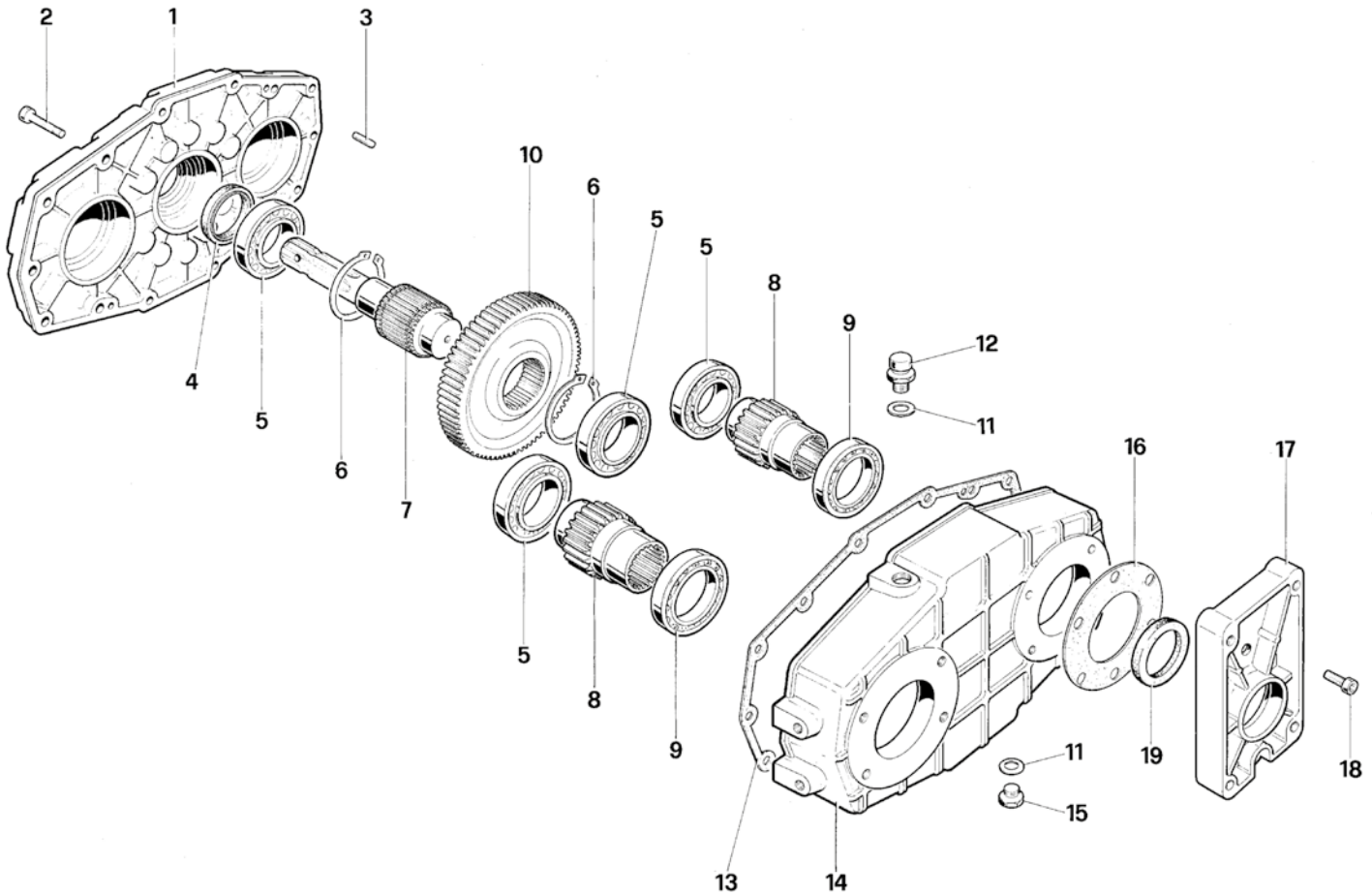

POS.	DENOMINAZIONE	DENOMINATION	DESCRIPTION	BEZEICHNUNG	Q.TA'
1	Coperchio	Couvercle	Cover	Deckel	1
2	Vite V.T.C.E.I	Vis V.T.C.E.I	Socket capscrew	Zylinderkopfschraube mit Innens.	14
3	Spina	Goupille	Peg	Stift durchm	2
4	Anello di tenuta	Bague d'Étancheité	Sealing ring	Dichtring, Durchm.	1
5	Cuscinetto 6210	Palier 6210	Bearing 6210	Kugellager 6210	4
6	Anello seeger UNI 7435 - 58	Circlip UNI 7435 - 58	Snap ring UNI 7435 - 58	Seegerring UNI 7435 - 58	2
7	Albero presa di forza maschio 1"3/8 Z6	Arbre prise de force mâle 1"3/8 Z6	Female P.T.O. shaft 1"3/8 Z6	Antriebswelle mit Innenverkeilung 1"3/8 Z6	1
8	Pignone	Pignon	Pinion gear	Ritzel	2
9	Cuscinetto tipo 6012	Palier 6012	Bearing 6012	Kugellager Type 6012	2
10	Corona	Couronne	Ring gear	Zahnkranz	1
11	Guarnizione	Joint	Gasket	Dichtung	2
12	Tappo sfiato olio 3/8" con asta livello	Bouchon reniflard huile 3/8" , avec tige nivel oil	Oil breather plug 3/8", whit pole level oil	Entlüftungsschraube 3/8"	1
13	Guarnizione	Joint	Gasket	Dichtung	1
14	Scatola	Carcasse	Housing	Gehäuse	1
15	Tappo scarico olio 3/8"	Bouchon vindage huile 3/8"	Oil drain plug 3/8"	Olablabschraube 3/8"	1
16	Guarnizione	Joint	Gasket	Dichtung	1
17	Flangia	Bride	Flange	Flansch .	1
18	Vite V.T.C.E.I	Vis V.T.C.E.I	Socket capscrew	Zylinderkopfschraube mit Innens.	4
19	Anello di tenuta	Bague d'Étancheité	Sealing ring	Dichtring, Durchm.	1

HIDRAULICA ROGIMAR, S.A.